

## 1 Unpacking

Open the carton and unpack the items. Your package should include:

- EG97000 Ethernet switch
- 2 Mounting brackets
- 12 Mounting screws
- 1 Console cable
- 1 AC Power Cord (optional)

If any items are missing or damaged, notify your EtherWAN representative. If possible, save the carton and packing material in case you need to ship or store the switch in the future.

## 2 What Else You Need

- Shielded twisted pair cables and corresponding shielded RJ45 connectors
- Appropriate SFP cable and SFP modules for SFP ports

## 3 Select a Location

- Installation: Rack-mount. Use the enclosed screws and brackets to mount the switch in an open or enclosed rack.
- Select a power source within 6 feet (1.8 meters).
- Choose a dry area with ambient temperature between -40 and 75°C (-40 and 167°F).
- 75°C for Models EG97244-4VZ (Z can be either WR, CR, and TR, or WR-CC, CR-CC, and TR-CC) (CR and CR-CC use in US/CSA only);
- Be sure there is adequate airflow.

## 4 Connect to the Data Ports

The EG97000 has the following ports:

- 8 x 10/100/1000 Mbps copper ports
- 16 x 100/1000 SFP slots
- 4 x 1/10G SFP+ slots
- 1 x RJ-45 Management port
- 1 x USB port

### 10/100/1000BASE-TX Ports

Ports 1 to 8 are gigabit copper ports and can be connected to routers, other switches, or end devices.

### 100/1000BASE SFP Slots

Ports 9 – 24 are 100/1000BASE SFP slots, for connection with stackable switches to form multiple fiber interconnections. Use appropriate SFP transceivers.

### 1/10 Gbps SFP+ Slots

SFP+ ports 1 – 4 are for uplink connection to core networks. Ensure that the same type of transceiver is used at both ends of the link and that the correct type of fiber cable is used.

## 5 Connect Power

### Terminal Block

If your EG97000 comes with AC power cables, connect the cables into the power modules at the back of the switch. If your switch comes with a DC or AC terminal block (no cable), then connect the switch to a suitable power supply using 12 to 24 AWG wire. Redundant power supply is supported. However, only one power input is required to operate the switch. Input voltage is 48 VDC or 100 – 240 VAC, depending on model.

### Relay Output Alarm

The switch provides one dry contact for signaling of a user-defined power or port failure. The alarm relay default is “open” and forms a closed circuit when the event occurs. The relay output can be connected to an alarm signaling device. Relay output current is 30VDC / 0.6A.

**NOTE:** The initial normal state of the relay is open, and if switch loses \*all\* power, then this state will come into effect. This is important to remember when using the relay to indicate a power failure. The relay will close in an alarm state when there is redundant power input and an alarmed input fails.

## 6 Front Panel LEDs

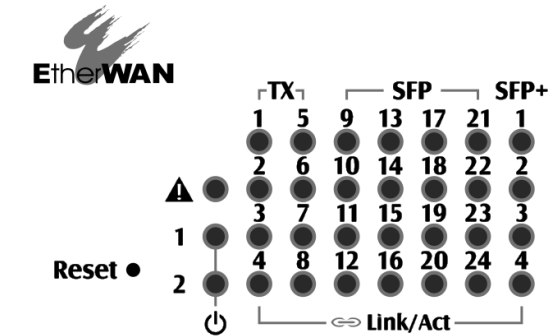

### Link/Act

**Green:** Network connection established

**Flashing:** Port sending or receiving data

**Red:** Link down or power down

**Reset Button:** Press and hold for less than 10 seconds to reboot the switch. Press and hold for more than 10 seconds to reset the switch to the default password.

## 7 Initial Configuration

Connect to the switch using the enclosed Ethernet cable to connect a serial port on a PC to the RJ-45 Management port located on the front panel next to the USB port. You can also use regular Ethernet cable to connect the RJ-45 port on the PC to any of the TX ports 1 - 8. The IP address of VLAN 1 is [192.168.1.10](http://192.168.1.10).

### Configuration via CLI

If using a terminal-emulation program such as Putty, configuration settings are: Baud rate: 115,200bps, Data bits: 8, Parity: none, Stop bit: 1, Flow control: none. The default login name is `root`, no password.

### Configuration via Web Browser

Log in to the switch by launching a web browser and entering [192.168.1.10](http://192.168.1.10) in the address bar. Enter the default login ID: `root` (no password) and click “Login.”

## 8 Copy Configuration to USB

The switch is equipped with one USB port (Type A connector) for configuration file and syslog backup. The USB port can be used to save the configuration and Syslog to a (FAT32) USB storage device.

Plug the device into the USB port, and use the “**Save Configuration**” command in the web interface, or “**copy running-config startupconfig**” in the CLI.

## 9 Other Electrical and Safety Information

A) Elevated Operating Ambient - If installed in a closed or multi-unit rack assembly, the operating ambient temperature of the rack environment may be greater than room ambient. Therefore, consideration should be given to installing the equipment in an environment compatible with the maximum ambient temperature (T<sub>ma</sub>).

B) Mechanical Loading - Mounting of the equipment in the rack should be such that a hazardous condition is not achieved due to uneven mechanical loading.

C) Circuit Overloading - Consideration should be given to the connection of the equipment to the supply circuit and the effect that overloading of the circuits might have on overcurrent protection and supply wiring. Appropriate

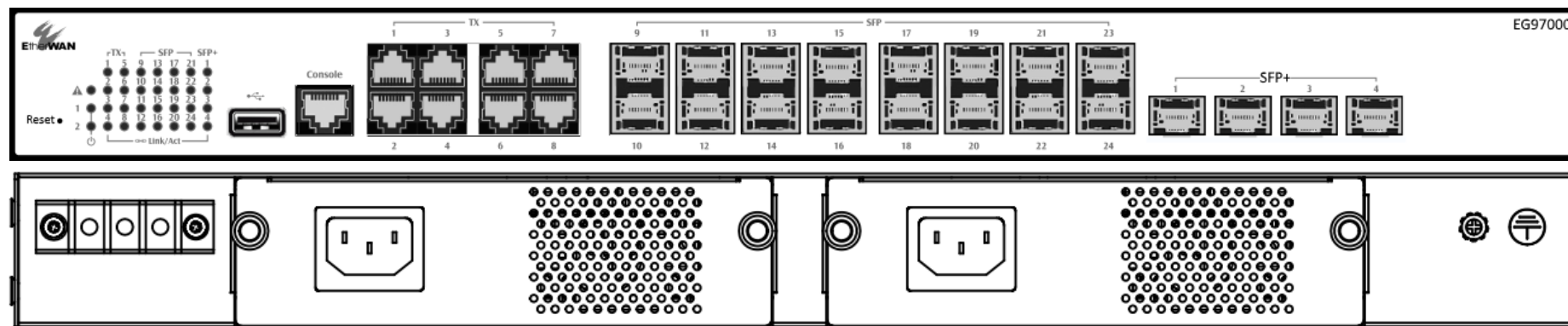

consideration of equipment nameplate ratings should be used when addressing this concern.

D) Reliable Earthing - Reliable earthing of rack-mounted equipment should be maintained. Particular attention should be given to supply connections other than direct connections to the branch circuit (e.g. use of power strips).

Do not disable the power cord grounding plug. The grounding plug is an important safety feature.

**Caution:**

This equipment shall be used with all power supplies connected simultaneously.



Hazardous voltages may occur within this unit when connected to all power supplies. Prevent access to hazardous voltages by disconnecting this equipment from all power supplies.



Plug the power cord into a grounded (earthed) electrical outlet that is easily accessible at all times.

This equipment is intended to be used in a restricted access location and by qualified personnel. This equipment is not suitable for use in locations where children are likely to be present.

**Les matériels sont destinés à être installés dans des EMPLACEMENTS À ACCÈS RESTREINT.**

This equipment must be connected to Protective earthing (PE) to AC mains ground. The protective earthing conductor shall be minimum 18 AWG and having green-and-yellow insulation. The thread diameter of screw type terminal shall be minimum 3.5mm.

The ground wire should be installed first (earlier than live and neutral wires) and then removed. The grounding wire should be longer than live and neutral wires. When wiring the switch to power, unscrew the two retaining screws that hold the protective cover in place. The metal protective cover should be reattached after the wiring is completed to avoid the danger of electric shock.

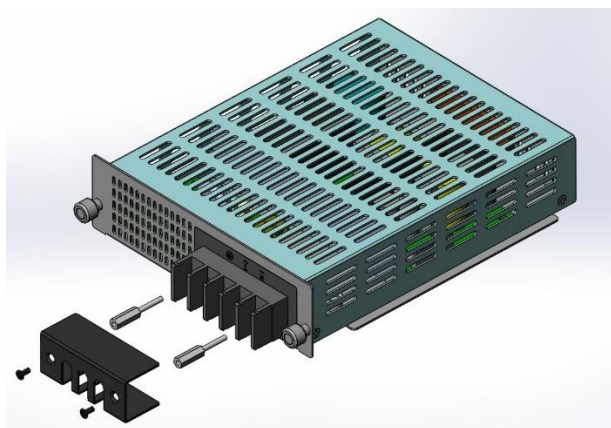

When stripping the cable sheath for connection to the terminal block, leave only 10mm of wires exposed for the connection.

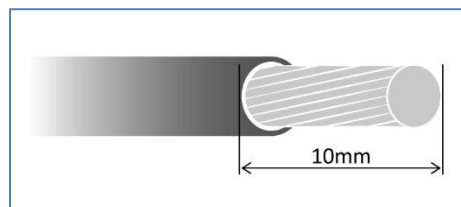

The power cord shall be IEC 60227 certified, rated 0.75 mm<sup>2</sup> x 3C or UL recognized minimum 18AWG.

**Terminal Block:**

This product is intended to be supplied by certified DC power source and rated output rating: 48 VDC, 1 A minimum.

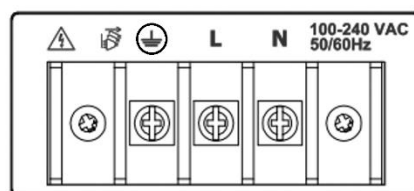
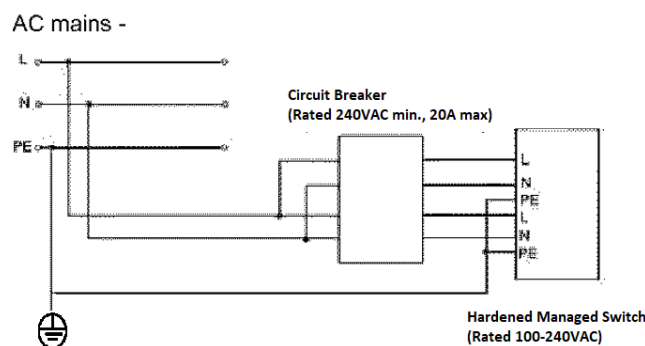
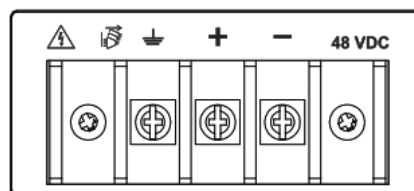

**AC Terminal Block**

AC power rating current is 0.6A. All power connection wiring by a qualified electrician in accordance with National Electrical Code, ANSI/NFPA 70 and Canadian Electrical Code, Part I, CSA C22.1. An IEC certified or UL listed single-phase type circuit-breaker, rated maximum 20A, shall be installed between mains circuit and equipment.

Thumbscrews should be tightened with a tool after both initial installation subsequent access to the panel.

**Note:**

This equipment must use UL recognized Laser Class 1 optical transceiver.

**Manufacturer information:**

**EtherWAN Systems, Inc.**

33F, No. 93, Sec. 1, Xintai 5th Rd., Xizhi Dist., New Taipei City, 221 Taiwan

The full product manual can be downloaded from:  
<https://www.etherwan.com/support/product/EG97000-series>

