

Quick Start Guide

This quick start guide describes how to install and use the Gigabit Ethernet media converter. The converter introduced here provides one channel media conversion solution.

Physical Description

Product Overview

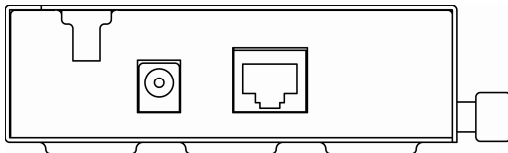

This Gigabit Ethernet media converter is a plug-and-play device. Connect the supplied AC to DC power adaptor to the receptacle on the front panel of the Gigabit Ethernet media converter, and then attach the plug into a standard AC outlet.

DIP Switch

No.	Down	Up
1	Disable LFPT	Enable LFPT
2	Enable Auto-Negotiation for TX port	Enable Force mode for TX port
3	TX port Force mode: Full-duplex	TX port Force mode: Half-duplex
4	TX port Force mode: 100Mbps	TX port Force mode: 10Mbps
5	Function reserved	Function reserved
6	Function reserved	Function reserved

<Note> LFPT: Link-Fault-Pass-Through function. Power must be off/on after re-setting LFPT function.

The 10/100/1000Base-TX and 1000Base-SX/LX/BX Connectors

The 10/100/1000Base-TX Connection

The following lists the pinouts of 10/100/1000Base-TX port.

Pin	Label
1	TP0+
2	TP0-
3	TP1+
4	TP2+
5	TP0-
6	TP1-
7	TP3+
8	TP3-

The 1000Base-SX/LX Connections

The fiber port pinouts

The Tx (transmit) port of device I is connected to the Rx (receive) port of device II, and the Rx (receive) port of device I to the Tx (transmit) port of device II.

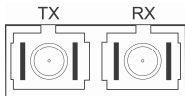

Gigabit Ethernet Media Converter

The WDM 1000Base-BX Connections
The fiber port pinouts
Only one optical fiber is required to transmit and receive data.

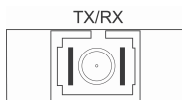

The Port Status LEDs

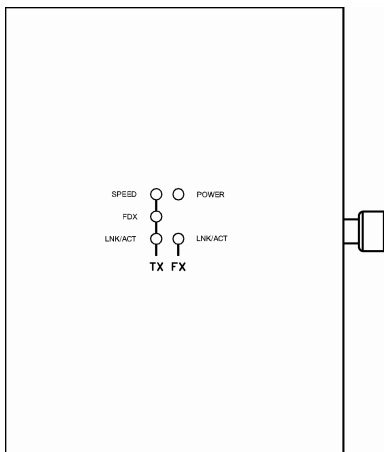

LEDs	State	Indication
POWER	Steady	Power on
	Off	Power off
SPEED (TX Port 10/100/1000Mbps)	Steady	Green: Connection at the speed of 1000Mbps Amber: Connection at the speed of 100Mbps
	Off	Connection at the speed of 10Mbps
LNK/ACT (TX)	Steady	A valid network connection is established on TX port LNK stands for LINK
	Flashing	Transmitting or receiving Data ACT stands for ACTIVITY
	Off	No network connection is established
FDX	Steady	TX port at Full-duplex mode FDX stands for Full-duplex
	Off	At Half-duplex mode
LNK/ACT (FX)	Steady	A valid network connection is established on Fiber port LNK stands for LINK
	Flashing	Transmitting or receiving Data ACT stands for ACTIVITY
	Off	No network connection is established

Functional Description

- Complies with IEEE802.3 10Base-T, IEEE802.3u 100Base-TX, IEEE802.3ab 1000Base-T, and IEEE802.3z 1000Base-SX/LX.
- Supports IEEE802.3x Flow control: Flow control for Full-duplex and Back pressure for Half-duplex.
- DIP switch configuration for "Link-Fault-Pass-Through".
- One fiber interface supports 1000Base-SX/LX/BX fiber transmission.
- Gigabit transmission supports 9K Bytes jumbo frame.
- 1000Mbps-Auto/Full-duplex, 10/100Mbps-Full/Half-duplex, Auto-Negotiation, Auto-MDI/MDIX.
- Full wire-speed forwarding rate.
- Built-in Fiber Tray, for ease of fiber cable management and installation.
- Operating voltage and Max. current consumption: 0.25A @ 12VDC. Power consumption: 3W Max.
- Power Supply: 12VDC external universal PSU.
- -5°C to 55°C (23°F to 131°F) operating temperature range.

FCC Statement

The FCC (Federal Communications Commission) restricts the amount of radio frequency emission and radiation coming from computer equipment.

The equipment introduced in this manual has been tested and found to comply with the limits for a Class A digital device pursuant to Part 15 of the FCC rules. These limits are designed to provide reasonable protection against harmful interference when the equipment is operated in a commercial environment.

This equipment generates, uses, and can radiate radio frequency energy, and if not installed and used in accordance with the instruction manual, may cause harmful interference to radio communications.

Operation of this equipment in a residential area is likely to cause harmful interference in which case the user is required to correct the interference at his/her own expense.

Any changes or modifications not expressly approved by the manufacture would void the user's authority to operate the equipment.

Trademarks

Product names mentioned in this manual may be trademarks or registered trademarks of those products.

All trademarks or brand names mentioned are properties of their respective companies.

Preface

This manual describes how to install and use the Gigabit Ethernet Media Converter. The Converter introduced here provides one channel media conversion solution:

10/100/1000Base-TX to 1000Base-SX/LX/BX with link-fault-pass-through function

The Gigabit Ethernet Media Converter fully complies with IEEE802.3 10Base-T, IEEE802.3u 100Base-TX, IEEE802.3ab 1000Base-T, and IEEE802.3z 1000Base-SX/LX Ethernet standards.

In this manual, you will find:

- Product overview
- Features on the media converter
- Illustrative LED functions
- Installation instructions
- Specifications

Table of Contents

QUICK START GUIDE	1
PHYSICAL DESCRIPTION	1
FUNCTIONAL DESCRIPTION	3
FCC STATEMENT	4
TRADEMARKS	4
PREFACE	4
TABLE OF CONTENTS	5
INTRODUCTION	6
PRODUCT OVERVIEW	6
PRODUCT FEATURES	6
PACKING LIST	7
ONE-CHANNEL MEDIA CONVERTER	8
PHYSICAL PORTS	8
PORT STATUS LEDS	8
INSTALLATION	10
SELECTING A SITE FOR THE EQUIPMENT	10
CABLE MANAGEMENT TRAY	10
CONNECTING TO POWER	12
SPECIFICATIONS	13

Introduction

The Gigabit Ethernet Media Converter provides one channel for media conversion between 10/100/1000Base-TX to 1000Base-SX/LX/BX with link-fault-pass-through function.

Product Overview

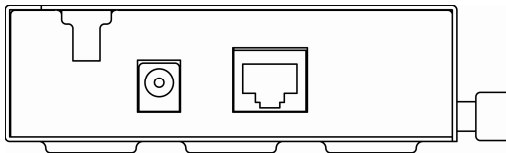

Figure 1:

Gigabit Ethernet Media Converter with link-fault-pass-through function

Product Features

- Complies with IEEE802.3 10Base-T, IEEE802.3u 100Base-TX, IEEE802.3ab 1000Base-T, and IEEE802.3z 1000Base-SX/LX.
- Supports IEEE802.3x Flow control: Flow control for Full-duplex and Back pressure for Half-duplex.
- DIP switch configuration for "Link-Fault-Pass-Through".
- One fiber interface supports 1000Base-SX/LX/BX fiber transmission.
- Gigabit transmission supports 9K Bytes jumbo frame.
- 1000Mbps-Auto/Full-duplex, 10/100Mbps-Full/Half-duplex, Auto-Negotiation, Auto-MDI/MDIX.
- Full wire-speed forwarding rate.
- Built-in Fiber Tray, for ease of fiber cable management and installation.
- Operating voltage and Max. current consumption: 0.25A @ 12VDC. Power consumption: 3W Max.
- Power Supply: 12VDC external universal PSU.
- -5°C to 55°C (23°F to 131°F) operating temperature range.

DIP Switch

No.	Down	Up
1	Disable LFPT	Enable LFPT
2	Enable Auto-Negotiation for TX port	Enable Force mode for TX port
3	TX port Force mode: Full-duplex	TX port Force mode: Half-duplex
4	TX port Force mode: 100Mbps	TX port Force mode: 10Mbps
5	Function reserved	Function reserved
6	Function reserved	Function reserved

<Note> LFPT: Link-Fault-Pass-Through function. Power must be off/on after re-setting LFPT function.

Packing List

When you unpack this product package, you will find the items listed below. Please inspect the contents, and report any apparent damage or missing items immediately to your authorized reseller.

- The Media Converter
- User's Manual
- AC to DC Power Adaptor

One-Channel Media Converter

Physical Ports

Gigabit Ethernet Media Converter

This converter provides one 10/100/1000Base-TX port and one 1000Base-SX/LX/BX fiber port. For the 1000Base-SX/LX/BX fiber port, it provides options of multi-mode/single-mode or WDM multi-mode/single-mode fiber. For the 10/100/1000Base-TX port, it uses RJ-45 connector and supports auto MDIX for uplink purpose.

Port Status LEDs

The LED indicators give you instant feedback on status of the converter:

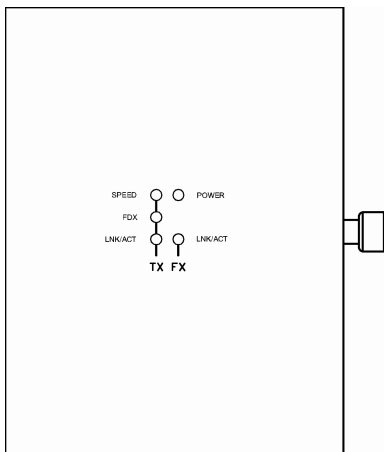

Figure 2:

Gigabit Ethernet Media Converter with link-fault-pass-through function

Gigabit Ethernet Media Converter

LEDs	State	Indication
POWER	Steady	Power on
	Off	Power off
SPEED (TX Port 10/100/1000Mbps)	Steady	Green: Connection at the speed of 1000Mbps Amber: Connection at the speed of 100Mbps
	Off	Connection at the speed of 10Mbps
LNK/ACT (TX)	Steady	A valid network connection is established on TX port LNK stands for LINK
	Flashing	Transmitting or receiving Data ACT stands for ACTIVITY
	Off	No network connection is established
FDX	Steady	TX port at Full-duplex mode FDX stands for Full-duplex
	Off	At Half-duplex mode
LNK/ACT (FX)	Steady	A valid network connection is established on Fiber port LNK stands for LINK
	Flashing	Transmitting or receiving Data ACT stands for ACTIVITY
	Off	No network connection is established

Installation

This chapter gives step-by-step installation instructions for the Converter.

Selecting a Site for the Equipment

As with any electric device, you should place the equipment where it will not be subjected to extreme temperatures, humidity, or electromagnetic interference. Specifically, the site you select should meet the following requirements:

- The ambient temperature should be between 23 and 131 degrees Fahrenheit (-5 to 55 degrees Celsius).
- The relative humidity should be less than 95 percent, non-condensing.
- Surrounding electrical devices should not exceed the electromagnetic field (RFC) standards for IEC 801-3, Level 2 (3V/M) field strength.
- Make sure that the equipment receives adequate ventilation. Do not block the ventilation holes of the equipment.
- The power outlet should be within 1.8 meters of the product.

Cable Management Tray

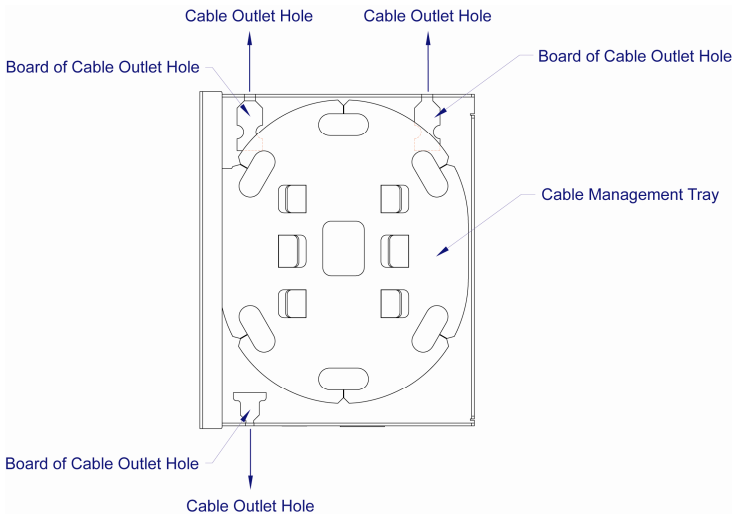

Cable management tray, board of cable outlet hole, and cable outlet hole.

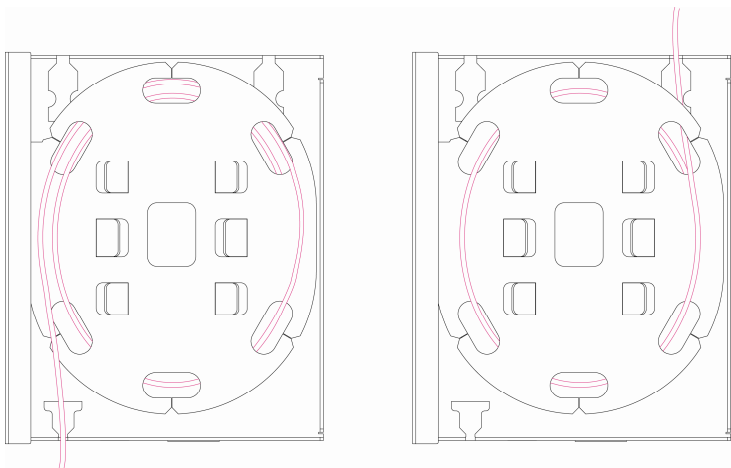

Route the fiber cable.

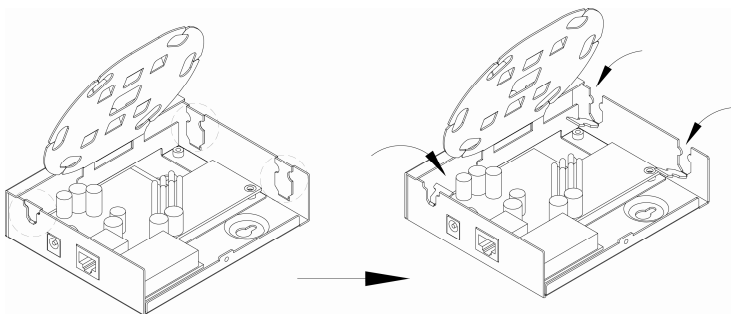

Bend the board of cable outlet hole.

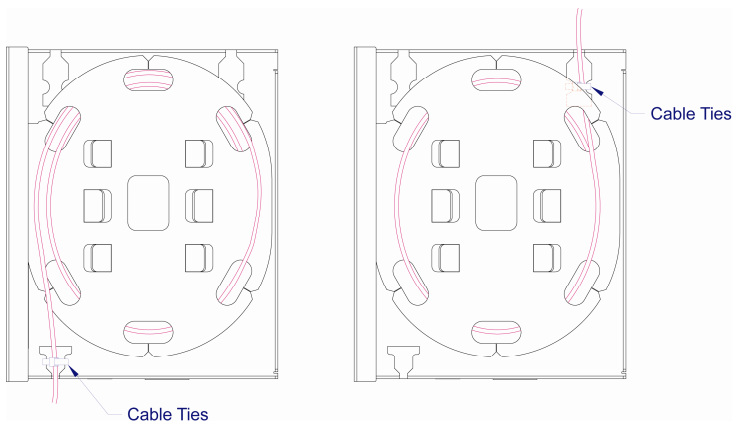

Cable ties.

Connecting to Power

This Converter is a plug-and-play device.

Connect the supplied AC to DC power adapter to the receptacle on the front panel of the converter. Attach the plug into a standard AC outlet.

Specifications

Applicable Standards	IEEE802.3 10Base-T IEEE802.3u 100Base-TX IEEE802.3ab 1000Base-T IEEE802.3z 1000Base-SX/LX
Fixed Ports 10/100/1000Base-TX to 1000Base-SX/LX/BX:	1 10/100/1000Base-TX port 1 1000Base-SX/LX/BX port
Speed 10Base-T 100Base-TX 1000Base-T 1000Base-SX/LX/BX	10/20Mbps for half/full-duplex 100/200Mbps for half/full-duplex 2000Mbps for full-duplex 2000Mbps for full-duplex
Forwarding rate	14,880pps for 10Mbps 148,810pps for 100Mbps 1,488,100pps for 1000Mbps
LED Indicators	Unit: POWER TX port: SPEED, FDX, LNK/ACT FX port: LNK/ACT
Dimensions	100mm (W) x 122mm (D) x 32.5mm (H) (3.94" (W) x 4.8" (D) x 1.28" (H))
Weight	0.5Kg (1.1lbs.)
Power	External power adaptor 0.25A @ 12VDC
Power Consumption	3W Max.
Operating Temperature	-5°C ~ 55°C (23 ~ 131°F)
Storage Temperature	-20°C ~ 70°C (-4°F ~ 158°F)
Humidity	5 ~ 95%, non-condensing
Emissions	CE Mark Class A FCC part 15 Class A VCCI Class A